

EP-300

Thermal Receipt Printer

EP-300 is a high-speed thermal receipt printer designed for 24/7 tasks for limited operating time applications, especially retail stores and Fast Food applications.

With the Low-noise mechanism, and reliable printer module, EP-300 can perform long-time printing and reduce the noise to the minimum. Multi I/O Interface, Easy maintenance and fascinating high-speed performance, EP-300 is the best choice of high-quality demand solutions.



Feature



250 mm/sec High-Speed Print Engine
(Paper Auto-Cutter support)



Multi I/O Interface support
(USB, Serial, Ethernet, RJ-11)

250
mm/sec
Thermal

Auto
Cutter

Multi-Fonts
Support

ESC/POS
Compatible

Serial
Ethernet
USB

576
dots/line

- Compact Design
- Paper Auto-Cutter
- Multi I/O Interface (Serial +Ethernet +USB)
- Cash drawer connection port (RJ-11)
- Compatible with ESC/POS print commands set
- Various Drivers available
- User friendly, drop-and-print paper installation, simple paper jam elimination
- Multiple Language fonts selectable

Specification

Model	ÛP-300
General	
Print Method	Thermal line printing
Print Speed	250mm/sec
Print Life	100 Km
Print Resolution	576 dots/line or 512 dots/line
Print Font Character Support	International Font, Big 5 Chinese, GB Chinese, Japanese, Korean selectable
Print Font	ANK Font Font A: 12 x 24 dots Font B: 9 x 17 dots Chinese character: 24 x 24 dots
Effective Print Width	72mm
Paper Width	79.5mm± 0.5mm
Paper Roll Diameter	83mm
Paper Thickness	0.06~0.08mm
Driver	Win 9X/Win ME/Win 2000/ Win 2003/Win NT/ Win XP/Win Vista/Win 7/Win 8, compatible with EPSON and SAMSUNG
Print Command	ESC/POS print commands set
Auto Cutter	Partial
Paper End Detection	Yes
Over-Heat Halt-on Protection	Yes
Interface	
Serial	Multi I/O Interface (Serial +Ethernet +USB)
Parallel	
USB	
Ethernet	
Cash Drawer	DC 24V/1A, 6-Wire RJ-11 Socket
Others	
Power Input	24VDC/2.5A (with External Adapter 100~240VAC 50/60Hz)
Color	Black
Compliance	FCC / CE / WEEE / RoHS
Weight	1220 g (without cable)
Dimension (L x W x H:mm)	174 x 144 x 124
Operating Temperature	0°C~45°C
Operating Humidity	10% ~ 80% RH non-condensing
Storage Temperature	-10°C~ 60°C
Storage Humidity	10% ~ 90% RH non-condensing

Dimension

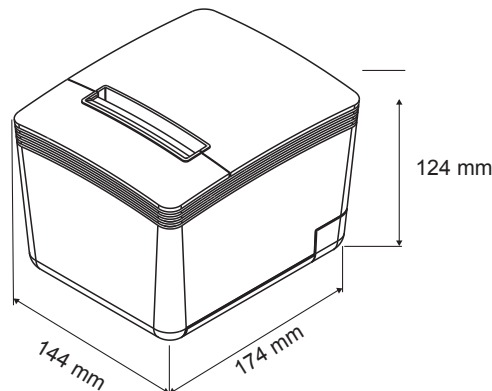

ISO-9002 Certified

